

OPERATOR'S MANUAL

VACUUM TUBE VOLT-OHMMETER MODEL 303

SIMPSON ELECTRIC COMPANY

5200 W. Kinzie St., Chicago 44, Illinois, ESTebrook 9-1121

In Canada, Bach-Simpson, Ltd., London, Ontario

Copyright 1958, Simpson Electric Co., Chicago

6-60-JM-BL

Printed in U.S.A.

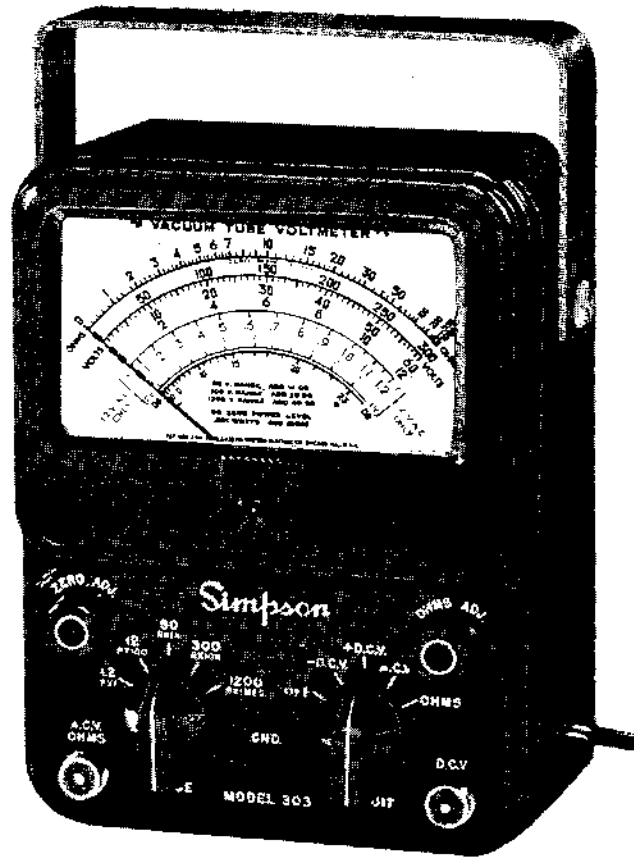

FIGURE 1. SIMPSON VACUUM TUBE VOLT-OHMMETER
MODEL 303

2

Courtesy of: Aubrey Morgan
& Simpson260.com

SECTION I

GENERAL DESCRIPTION

INSTRUMENT

The Simpson Model 303, as shown in figure 1, offers the service and research field a small, compact and rugged vacuum tube volt-ohmmeter, complete in every detail. The high input impedance and frequency response gives this instrument the characteristics necessary in dealing with the high resistance circuits and high frequencies encountered in FM and television receiver servicing.

ROLL TOP MODEL

The Model 303 RT is the same instrument supplied with a convenient, all bakelite, roll top carrying case with a lead compartment sufficiently large to house the leads and line cord.

TEST LEADS

The Model 303 is supplied with a DC test probe, an AC and ohms test probe and a ground lead. An alligator clip is also supplied and may be slipped over the end of the test probe if desired.

POWER REQUIREMENTS

The Model 303 is designed for operation on a nominal 115 volt, 60 cycle line.

ACCURACY

Accuracy is 3% D.C. and 5% A.C. (60 cycle sine wave) of full scale deflection.

GENERAL DESCRIPTION

ACCESSORY PROBE

A Crystal R.F. Probe may be purchased as an accessory for making R.F. voltage measurements (signal tracing).

ELECTRICAL SPECIFICATIONS

The Model 303 covers seven major functions in the measurement and testing of modern FM and TV receivers and in laboratory and research work, as follows:

D.C. VOLTAGE

Ranges - 1.2, 12, 60, 300, 1200

Input resistance - 10 megohms for all ranges

D.C. Probe - With one megohm isolating resistor

Polarity Reversing Switch

OHMS

Ranges - 1000 (10 ohms center)

100,000 (1000 ohms center)

1 megohm (10,000 ohms center)

10 megohms (100,000 ohms center)

1000 megohms (10 megohms center)

A.C. VOLTAGE

Ranges - 1.2, 12, 60, 300, 1200 volts

Impedance (with cable) approximately 210 uuf shunted by 275,000 ohms.

A.F. VOLTAGE

Ranges - 1.2, 12, 60 volts

Frequency Response - Flat to 100,000 cycles

GENERAL DESCRIPTION

DECIBELS

Zero Power Level = 1 milliwatt in 600 ohms

5 Ranges

-20 to +63 DB

GALVANOMETER

Zero Center for FM discriminator alignment

R.F. VOLTAGE (SIGNAL TRACING)

(With Accessory High Frequency Probe)

Range - 20 volts maximum

Frequency - Flat 20kc to 100mc

Capacity of Probe - 2.5uuf

VOLTAGE MEASUREMENTS DC

DC voltage is measured by applying the voltage through a voltage divider to the grid of one section of a 12AU7 tube. This causes an unbalanced condition between the two sections of the tube resulting in an indication on the meter proportional to the voltage applied.

VOLTAGE MEASUREMENTS AC

AC voltage is measured by applying the voltage directly or through a voltage divider to the plates of a 6AL5 tube where it is rectified and then measured the same as DC.

RESISTANCE DC

DC resistance is measured by applying a voltage from an internal battery to the grid on one section of the 12AU7 tube through a voltage dividing network. This causes an unbalanced condition between the sections of the tube result-

GENERAL DESCRIPTION

ing in a deflection of the meter proportional to the resistance being measured.

SECTION II

OPERATION

CAUTION

When making high voltage measurements, it is advisable to slip the alligator clip over the test probe and clip the lead to the desired point with the power to the circuit turned off. Then turn on the power and take the reading. Turn off the power to disconnect the probe.

ZERO ADJUSTMENT (MECHANICAL)

Before turning on the power to the Model 303, be sure that the pointer is on zero. If pointer is off zero, adjust by means of the slotted screw located in the bakelite case directly below the meter scale. Use a small screwdriver to turn this adjustment slowly right or left until the pointer is directly over the zero point on the scale.

OPERATION OF CONTROLS

CIRCUIT SELECTOR SWITCH

When the CIRCUIT selector switch is in the OFF position, the power is turned off. Turning this switch to the right turns on the power and also selects the circuit to be used. The two positions are marked +D.C.V. and -D.C.V. They constitute a meter reversing switch and indicate the po-

OPERATION

larity of the D.C. probe lead. This makes it possible to keep the ground lead connected to the chassis or the common connection to read either polarity, and to use the probe lead to check voltages at various points in the circuit.

In the A.C.V. position the circuit is arranged for A.C. voltage measurements through use of a vacuum tube rectifier.

In the OHMS position an internal battery and associated resistors are switched into the circuit to provide for resistance measurements.

The A.C.V.—OHMS probe is used for both A.C. Volts and resistance measurements.

RANGE SELECTOR SWITCH

The RANGE selector switch selects the desired range for the circuit indicated by the position of the circuit selector switch.

ZERO ADJUSTMENT (ELECTRICAL)

After the power has been turned on and the circuit selector switch placed in one of the voltage measuring positions, the knob marked ZERO ADJ. should be turned to the right or left until the pointer is directly over the zero point on the scale. When making this adjustment, the probe being used should be connected to the ground lead. When changing ranges or circuits it may be necessary to readjust zero.

OHMS ADJUSTMENT

With the circuit selector switch placed in the OHMS position and the range selector switch in one of the resistance measuring positions, the pointer will rest near the

OPERATION

right end of the scale (test leads open). The knob just to the right of the meter marked OHMS ADJ. should be turned right or left until the pointer is directly over the mark at the right end of the scale, the point of infinite resistance.

MEASURING D.C. VOLTAGES

1. Place the circuit selector switch in the +D.C.V. or -D.C.V. position depending upon the polarity of the voltage to be measured.
2. Rotate the range selector switch to any one of the five voltage positions (1.2 to 1200V) required. While the 303 will not be damaged easily, select a range higher than the voltage to be measured. After the first reading, the switch can be reset to a lower range, if needed, to get a more accurate reading.
3. Plug the black test lead into the jack marked GND. and clip the other end to the common side of the circuit to be checked. Connect the DC probe to the connector marked D.C.V.
4. Turn on the power to the circuit under test and place the end of the probe on the point to be checked. If desired, an alligator clip may be slipped over the end of the probe and clipped to the point to be checked before the power is turned on. If the meter deflects to the left of zero, the polarity is incorrect and the circuit selector switch should be placed in the other D.C.V. position.
5. Read the voltage on the black arc second from the top marked VOLTS reading the figures as follows:

1.2 volt range - read 0-12 and divide by 10

OPERATION

- 12 volt range - read 0-12 directly
- 60 volt range - read 0-60 directly
- 300 volt range - read 0-300 directly
- 1200 volt range - read 0-12 and multiply by 100

ZERO CENTER DC VOLTS

1. Place the circuit selector switch in the position marked -D.C.V. or +D.C.V. With the D.C. probe connected to the ground lead, rotate the ZERO ADJ. knob until the meter pointer is exactly over the red line marked ZERO CENTER.
2. Rotate the range selector switch to a range at least twice the probable voltage to be measured and make connections as for D.C. volts.
3. Observe the indication on the arc of the scale marked VOLTS. Positive voltage on the probe lead will be indicated to the right of center and negative voltage to the left of center with the selector switch set at +D.C.V. Each side represents one-half of the range being used. For example, when the 60 volt range is being used, each half of the scale represents 30 volts and each division 1 volt.

The purposes for which the zero center scale is used usually do not require an accurate measurement of voltage but merely an indication of a balanced condition. Such a use is illustrated in the alignment of a discriminator where a balanced condition will result in a zero center indication while an unbalanced condition will cause either a positive or negative deflection.

OPERATION

MEASURING A.C. VOLTS

1. Place the circuit selector switch in the position marked A.C.V.
2. Rotate the range selector switch to any one of the five voltage positions required from 1.2 to 1200 V.
3. Plug the black test lead into the jack marked GND. and clip the other end to the common side of the circuit to be checked. Connect the AC probe to the connector marked A.C.V.
4. Turn on the power to the circuit under test and hold the point of the probe against the point to be checked. To avoid accidental shock, keep the free hand away from the chassis or any part of the circuit.
5. For the 1.2 volt range read the voltage on the red arc third from the top marked 1.2V AC ONLY reading the figures directly. For the other ranges use the black arc second from the top, reading the figures as follows:

12 volt range - read 0-12 directly

60 volt range - read 0-60 directly

300 volt range - read 0-300 directly

1200 volt range - read 0-12 and multiply by 100

VOLUME LEVEL MEASUREMENTS

Connect the Model 303 as for AC voltage measurements. When using the 1.2 volt range read decibels on the red DB scale.

When using the 12 volt range read decibels on the black DB scale.

OPERATION

When using the 60, 300 or 1000 volt range, use the black DB scale and add to the reading the number of DB appearing opposite the range in the chart directly below the DB scales. The zero power level is .001 watt in 600 ohms. Conversion may be made to the .006 watt -500 ohm level by adding algebraically -7 DB.

RESISTANCE MEASUREMENTS DC

1. Place the circuit selector switch in the position marked OHMS.
2. Rotate the range selector switch to any one of the five ranges required (R x 1 to Rx1MEG).
3. The pointer will rest near the right end of the scale (without test leads shorted). Adjust OHMS ADJ. control until meter reads full scale. With leads shorted, meter should read zero (left end of scale). It may be necessary to adjust the ZERO ADJ. knob with leads shorted after which the full scale point should be rechecked with the test leads open.
4. Plug the black test lead into the jack marked GND. Connect the OHMS probe to the connector marked OHMS.
5. Read ohms on the top arc of the scale marked OHMS. Read the figures as follows:

Rx1 (1000 ohms) range - read 0 - 1000 directly
Rx100 (100,000 ohms) range - multiply by 100
Rx1K (1,000,000 ohms) range - multiply by 1000
Rx10K (10,000,000 ohms) range - multiply by 10,000
Rx1 MEG (1,000,000,000 ohms) range - multiply by
 1,000,000

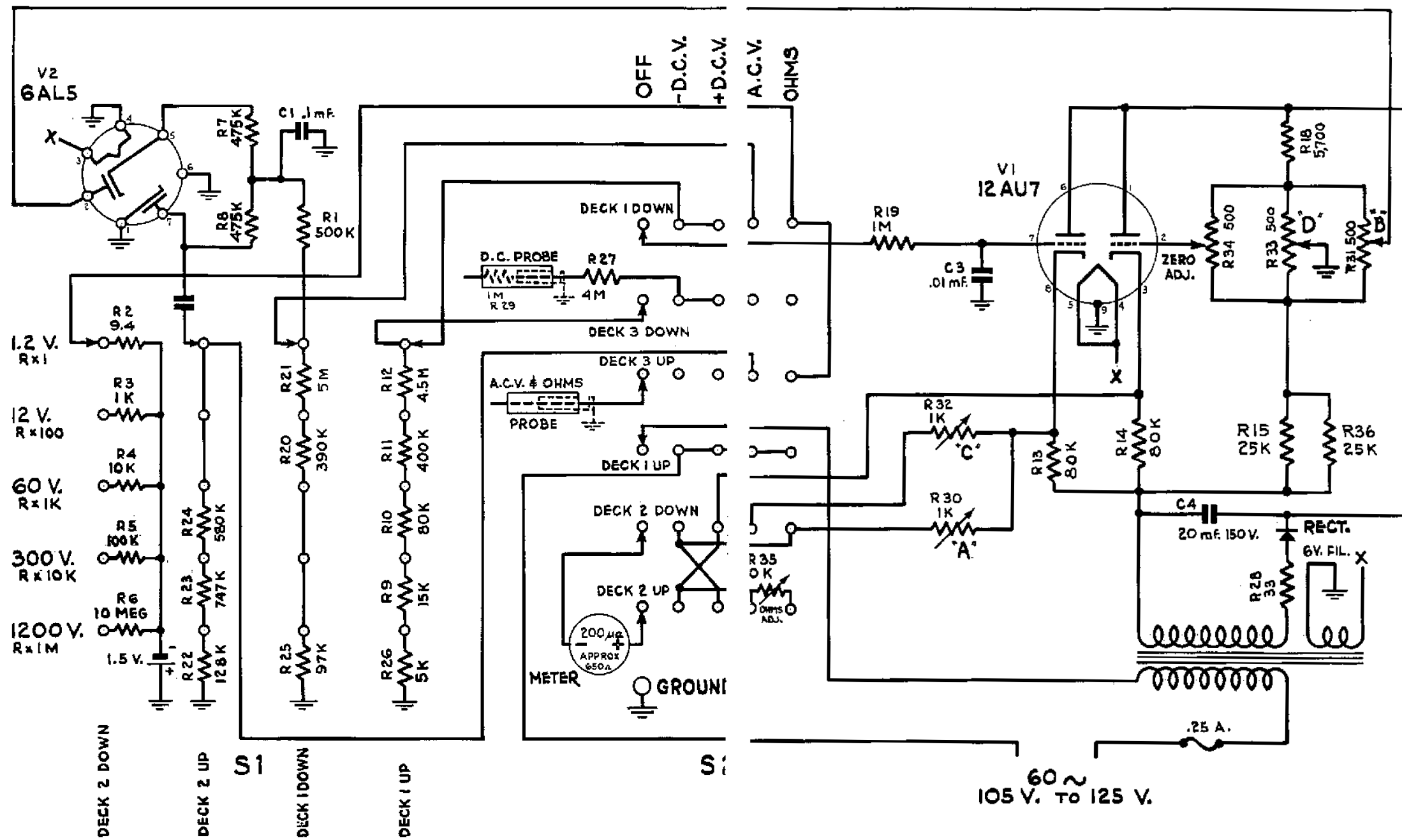

FIGURE 2. SIMPSON VACUUM TUBE VOLT OHMMETER MODEL 303, SCHEMATIC DIAGRAM

SECTION III

MAINTENANCE

CARE

The Model 303 is a very rugged instrument designed to take the wear and tear of every day service work. Nevertheless, it should receive the care given to other fine electronic equipment and care should be used against dropping or other excessively rough treatment.

REPLACEMENT OF BATTERY

The 1.5V battery used as a current source for the ohmmeter will give a long service in the Model 303 but when replacement is necessary, a new battery can be slipped into the clamp holding the battery in place. It will be necessary to remove the Model 303 from its case which can be done by removing the four screws in the bottom of the case. When inserting the battery, be certain that the polarity is correct.

CALIBRATION

The Model 303 has been carefully calibrated at the factory and no further changes should be necessary. However, in case recalibration is required at any time, use the following procedure:

1. Allow the Model 303 to warm up for approximately 1 hour. Place the range selector switch in the 1.2 V position.
2. Place the circuit selector switch in the -D.C. position. Turn the ZERO ADJ knob to the extreme right and note

MAINTENANCE

the reading on any scale. Then turn the circuit selector switch to the +D.C. position and turn the ZERO ADJ to the extreme left. Note the reading.

If there is any difference between the two readings in the above step, adjust potentiometer "D" (located inside the instrument) until these two readings are approximately equal.

3. Place the circuit selector switch in the -D.C. position. Adjust the ZERO ADJ knob so the meter indicates zero. Place the circuit selector in the A.C.V. position and adjust potentiometer "B" (located on the chassis) until the meter indicates zero.
4. Place the circuit selector switch in the -D.C. position and set the range selector switch to the 1.2 V range. Apply a known D.C. voltage to the D.C. probe which has a corresponding polarity and is within the limit of the range selected. Adjust potentiometer "A" (located on the chassis) until the meter indicates the calibrating voltage correctly. For calibration at the factory, a voltage is selected which will provide about 2/3 of full scale deflection.
5. Place the circuit selector switch in the A.C.V. position and apply a known A.C. voltage to the A.C. probe. Adjust potentiometer "C" (located on the chassis) until the meter indication corresponds to the known voltage.

REPLACEMENT OF TUBES

The 6AL5 tube is used as a rectifier for A.C. voltages. The 12AU7 tube is used in the bridge circuit for all measurements.

MAINTENANCE

When replacing a tube, it is advisable to use a tube which has been aged for 48 hours (connected in a circuit with a small amount of plate current flowing). If the two sections of the tube vary too much in characteristics, the calibration will be affected; also the zero shift between ranges will be greater than normal.

REPLACEMENT OF PARTS

If it becomes necessary to replace any other parts, order the replacement parts from the Simpson factory. Use the following parts list to obtain the correct Simpson part number for each part, and specify the part number in your order.

PARTS LIST

Reference Symbol	Description	Simpson Part No.
R1	Resistor, 500K ohms	1-114090
R2	Resistor, 9.4 ohms	0-008290
R3	Resistor, 1K ohms	1-113542
R4	Resistor, 10K ohms	1-113306
R5	Resistor, 100K ohms	1-113427
R6	Resistor, 10 Megohms	1-113434
R7	Resistor, 475K ohms	1-114180
R8	Resistor, 475K ohms	1-114180
R9	Resistor, 15K ohms	1-113347
R10	Resistor, 80K ohms	1-113285
R11	Resistor, 400K ohms	1-114092
R12	Resistor, 4.5 Megohms	1-114093
R13	Resistor, 80K ohms	1-113313
R14	Resistor, 80K ohms	1-113313

MAINTENANCE

R15	Resistor, 25K ohms	1-113426
R18	Resistor, 5,700 ohms	1-114198
R19	Resistor, 1 Megohm	1-113392
R20	Resistor, 390K ohms	1-113502
R21	Resistor, 5 Megohms	1-113433
R22	Resistor, 128K ohms	1-114095
R23	Resistor, 747K ohms	1-114096
R24	Resistor, 580K ohms	1-114200
R25	Resistor, 97K ohms	1-114119
R26	Resistor, 5K ohms	1-113425
R27	Resistor, 4 Megohms	1-113362
R28	Resistor, 33 ohms	1-114098
R29	Resistor, 1 Megohm	1-113392
R30	Potentiometer, 1000 ohms	1-114079
R31	Potentiometer, 500 ohms	1-114182
R32	Potentiometer, 1000 ohms	1-114079
R33	Potentiometer, 500 ohms	1-114182
R34	Potentiometer, 500 ohms	1-114181
R35	Potentiometer, 10K ohms	1-114142
R36	Resistor, 25K ohms	1-113426
C1	Capacitor, 0.1 μ f, 400 v, paper	1-113902
C2	Capacitor, 0.25 μ f, 400 v, paper	1-113903
C3	Capacitor, 0.01 μ f, 400 v, paper	1-113896
C4	Capacitor, 20 μ f, 150 v, electrolytic	1-114105
S1	Switch, 5 position Range	1-114072
S2	Switch, 5 position Circuit	1-114073
	Knob for S1 and S2	3-260180
	Knob for ZERO ADJ and OHMS ADJ	1-113641
	Fuse, 1/4 amp, 8AG	1-114103

MAINTENANCE

V1	Tube Socket, 9 pin miniature	10-890064
V2	Tube Socket, 7 pin miniature	10-890065
	Chassis connector (A.C. probe)	10-890063
	Chassis connector (D.C. probe)	10-890063
	Cable connector (A.C. probe)	10-890066
	Cable connector (D.C. probe)	10-890066
	Tip Jack (Ground lead)	1-111728
	Complete A.C. probe assembly	10-890068
	Complete D.C. probe assembly	10-890067
	Complete ground lead assembly	10-890069
	Case, complete with handle	3-320091
	Case, roll top, complete with inside case and handle	0-006379
	Meter and panel	15-302303
	Power transformer	10-890062
	Resistor housing	3-260211
	Battery 1.5 v	1-111801
	Tube, 12AU7	1-114083
	Tube, 6AL5	1-114084
	Line cord holder	3-260214
	Carrying handle	1-113283
	Selenium Rectifier	1-113619

SECTION IV APPLICATIONS

The high input resistance of the Simpson Volt-Ohmmeter Model 303 permits its use in many applications where a voltmeter of lower sensitivity would cause excessive cir-

APPLICATIONS

cuit loading. The following suggestions are only a few of the uses for which it will be found a superior instrument.

PLATE VOLTAGE MEASUREMENTS

Inaccurate readings of plate voltage often result when a low resistance voltmeter is used, especially in the case of high mu tubes which require high values of plate resistors. Such voltage can be accurately measured with the Simpson Volt-Ohmmeter Model 303, its low current drain resulting in a true reading.

PHASE INVERTER BALANCE

The two sections of a phase inverter circuit may be checked for balance with the Simpson Volt-Ohmmeter Model 303. With an audio signal generator connected to the input of the audio amplifier, the voltages at the grids and plates may be measured.

MEASUREMENT OF STAGE GAIN

The Simpson Volt-Ohmmeter Model 303 is an ideal instrument for measuring stage gain. The output of the signal generator may be checked and the amplified signal then measured at the plate of the tube of the stage being tested. The ratio of the voltage at input and output of a stage represents the stage gain.

AVC VOLTAGE

The use of the Simpson Volt-Ohmmeter Model 303 to measure AVC voltage is possible because the high input resistance of the Simpson Volt-Ohmmeter Model 303 has very little loading effect on such a circuit. Connecting the

APPLICATIONS

Model 303 across the AVC network is often more convenient than using an output meter for alignment purposes, as the volume control may be set at its minimum position, and it is not necessary to disconnect the AVC to prevent it from interfering with the alignment procedure.

DISCRIMINATOR ADJUSTMENT

The zero center mark on the dial of the Simpson Volt-Ohmmeter Model 303 permits easy adjustment of a discriminator stage. Connected across the load resistors, the reading will be zero when in balance but will deflect to the right or left if the stage is unbalanced.

FM ALIGNMENT

By connecting the Simpson Volt-Ohmmeter Model 303 across the load resistor of the limiter, a reading may be obtained for alignment purposes. Adjust the circuits for maximum indication. Manufacturer's instructions should be followed for exact procedure.

GRID VOLTAGE

The high input resistance of the Simpson Volt-Ohmmeter Model 303 makes it possible to measure voltage at the grids of tubes without excessive loading of the circuit. For example, the output of a local oscillator may be checked throughout the tuning range.

BIAS VOLTAGE

Bias voltages can be read accurately with the Simpson Volt-Ohmmeter Model 303. Its input resistance is so high that when connected across a bias resistor, the additional current drain is negligible.

APPLICATIONS

COUPLING AND BY-PASS CONDENSERS

Inasmuch as a condenser presents low impedance to AC current, readings may be taken on both sides of the condenser and should be approximately the same unless the condenser is defective.

SIGNAL TRACING

The Simpson Volt-Ohmmeter Model 303 is very useful in signal tracing or examining a radio circuit at various points in audio or radio frequency circuits. Its low capacity HF probe permits it to be used on high frequencies found in FM and television work.

SECTION V

ACCESSORY HIGH FREQUENCY PROBE

FOR MODEL 303 VACUUM TUBE VOLT-OHMMETER

GENERAL DESCRIPTION

Frequency Response	Flat within $\pm 10\%$ from 20 KC to 100 MC
Voltage Range	0 - 20 Max. peak volts
Probe Input Capacity	2.5 μf
Meter Calibration	R.M.S. value of sine wave
Meter Calibration Accuracy	$\pm 7.5\%$ of full scale

The H.F. Probe for the Simpson Model 303 is designed for use on frequencies above the range of the regular A.C. probe furnished with the meter. The cable terminates with the same type of connecting plug.

ACCESSORY PROBE

The crystal diode in the probe body rectifies the voltage under test, charging the .01 uf capacitor proportionate to the positive peak value. This direct current is then fed through a resistor and into the D.C. input of the meter circuit where it is read directly on the scale in R.M.S. values. To convert meter reading to peak value multiply by 1.414.

OPERATING INSTRUCTIONS

Connect the plug on the end of the cord to the jack marked D.C.V. and set the CIRCUIT selector switch to -D.C.V. Set the RANGE selector switch to the desired range. Connect the alligator clip to a ground connection and touch tip of probe to point being measured.

For the 1.2 volt range read voltage on the red scale marked 1.2 V A.C. ONLY.

For the 12 and 60 volt ranges read the black scale for volts. Note that the limit for voltages is 20 volts peak. This is 14.14 volts R.M.S. on the 60 volt range.

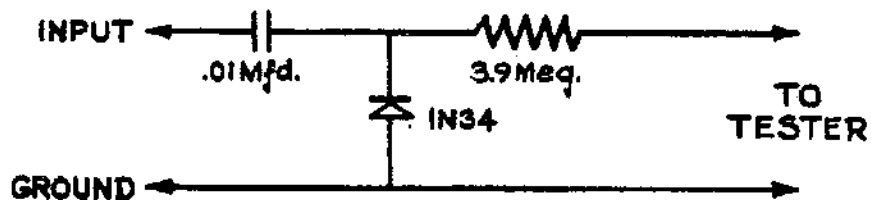
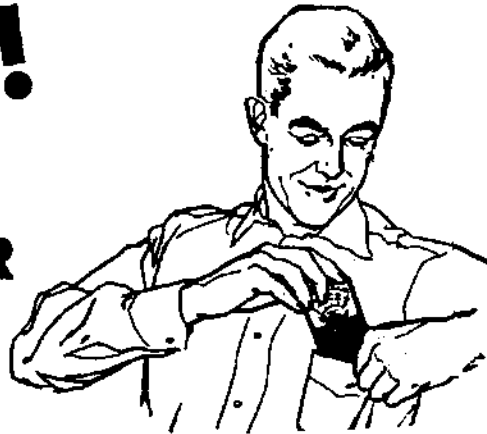

FIGURE 3. HIGH FREQUENCY PROBE FOR SIMPSON MODEL 303, SCHEMATIC DIAGRAM

NEW!
Simpson
MIDGETESTER
 ... SELF MODEL 355
 SHIELDED!



(not affected by steel-topped benches, heavy current carrying circuits, stray magnetic fields, etc.)



Here's the first practical shirt-pocket volt-ohmmeter commercially available. Although it measures *only* 2¾" x 4½" x 1" over-all, it's a practical working instrument with ruggedness and accuracy of testers many times larger. Has a sensitivity of 10,000 ohms per volt on both AC and DC! Fourteen measurement ranges are available *five for AC voltages, five for DC voltages, and four for DC resistances.* A perfect instrument for all electrical and electronic servicemen.

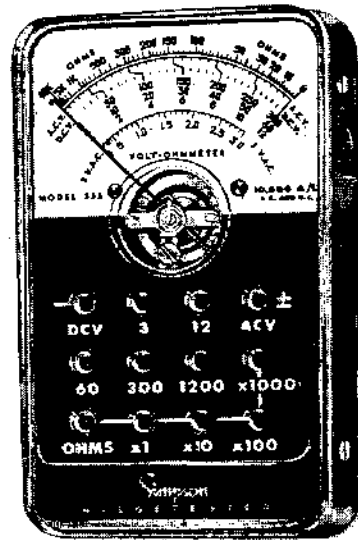

RANGES, DC AND AC VOLTAGE: 3, 12, 60, 300, 1200.

DC RESISTANCES: 0-10K ohms (120 ohms center);
 0-100K ohms (1200 ohms center); 0-1 megohm
 (12K ohms center); 0-10 megohms (120K ohms
 center).

Size; 2¾" wide, 4½" high, and 1" thick. Weight; 7 oz.

Model 355 with Leads, Operator's Manual..... **\$34⁹⁵**

Zipper Type Carrying Case No. 6355.....**\$3.95**

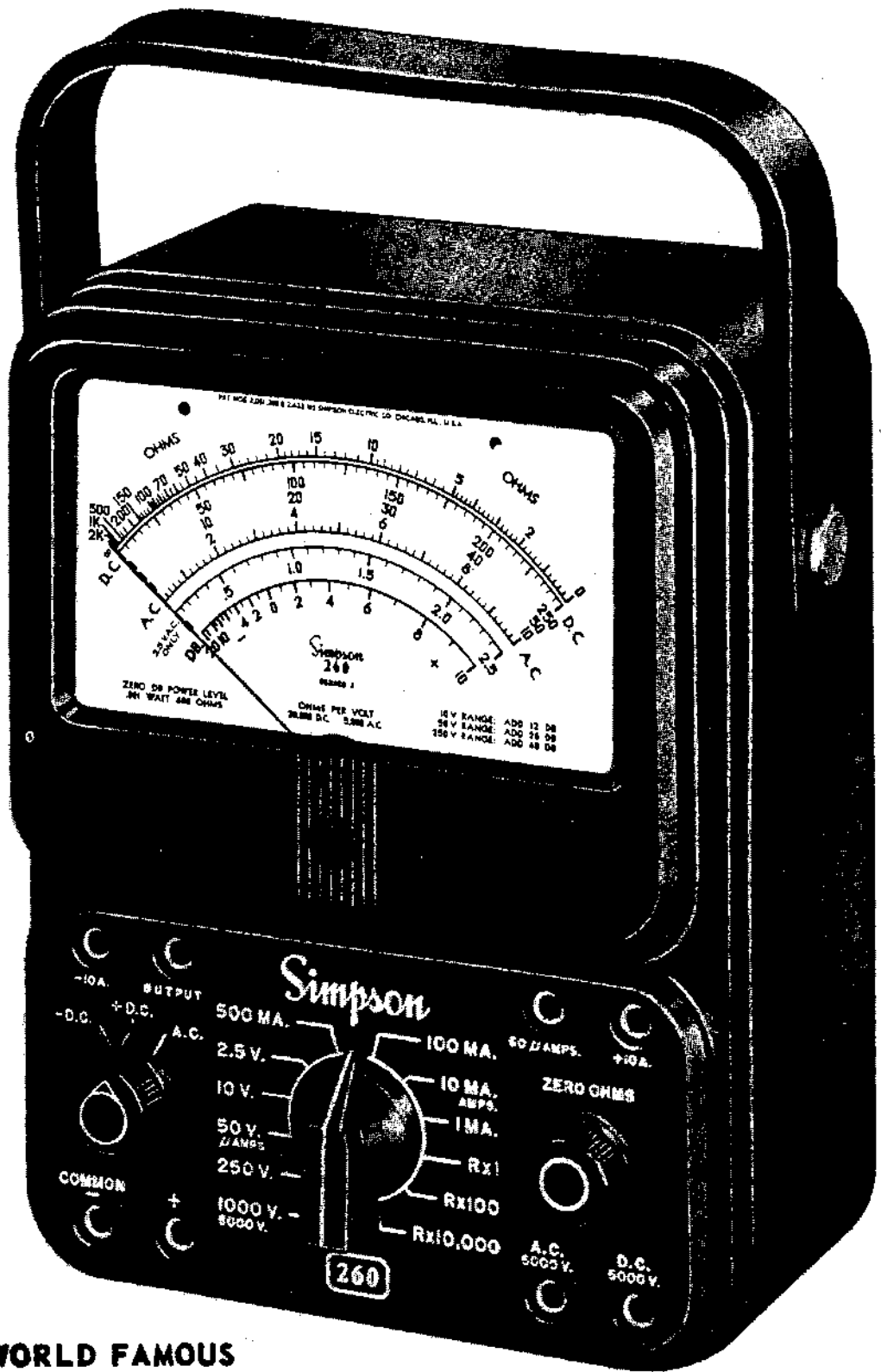

WORLD FAMOUS
"260" V.O.M. still only \$43.95